

PMD Model SIGMA-3

PMD PACKAGING SYSTEMS (PTY) LTD

PMD PACKAGING SYSTEMS

www.pmdpackaging.co.za

Vertical packaging machines are high speed form, fill and seal machines, suitable for most products such as granulates, powders, liquids or snack foods. Operating with impulse welding or heat sealing systems for different wrapping materials, e.g pure polythene, cellophane, polypropylene, paper/polythene, aluminum /polythene or similar combinations.

Dosing system such as volumetric cup filler, auger filler, multi head weighers can be fitted. Programmable and individually adjustable functions guarantee maximum efficiency for every packaging process.



Machine Controls

10" Touch Sensitive Screen,
All icon driven to minimize need for language skills,
Access Control to suit customer,
Comprehensive Graphics Production / Management
Information Display,
Alarm Reports.
Machine Status Signal Light Tower,
Diagnostics,
Emergency Default Program

Machine Specification

Belt drive for film advance,
Quick change former assembly,
Quick change vertical and horizontal sealing parts,
Full safety guarding and interlocks,
Low level film alarm,
Aspiration facility,
Pneumatic reel feed brake,
Lower machine height with maximum bag use

Additional Options

- Hole Punch
- Euroslot
- Tear Notch
- Date Coding
- Block Bottom Bags
- Nitrogen Flush
- Cut & Count
- Product Clamp
- Film Splice Assist
- Through Jaw Product Stripper

TECHNICAL DATA

Bag width: 80 to 240mm

Bag length: 50 to 350mm

Max mechanical operating speed: 100 cycles / minute
Nominal output - 85 bags / minute
Depending on packaging material,
product and weight.

Reel diameter: 500mm
Reel core diameter: 70mm
Electrical Data: 380V/50Hz/3PH

Consumption: 6KVA

Compressed Air: Requirement: 6 Bar

Usage Cello: 5NL/Cycle
Poly: 10 NL/Cycle

Water: Not Required

Finish: Powder coated, metalised finish

Product contact parts: Stainless steel,
Zinc or Nickel plated.

Weight: Approximately 800kg

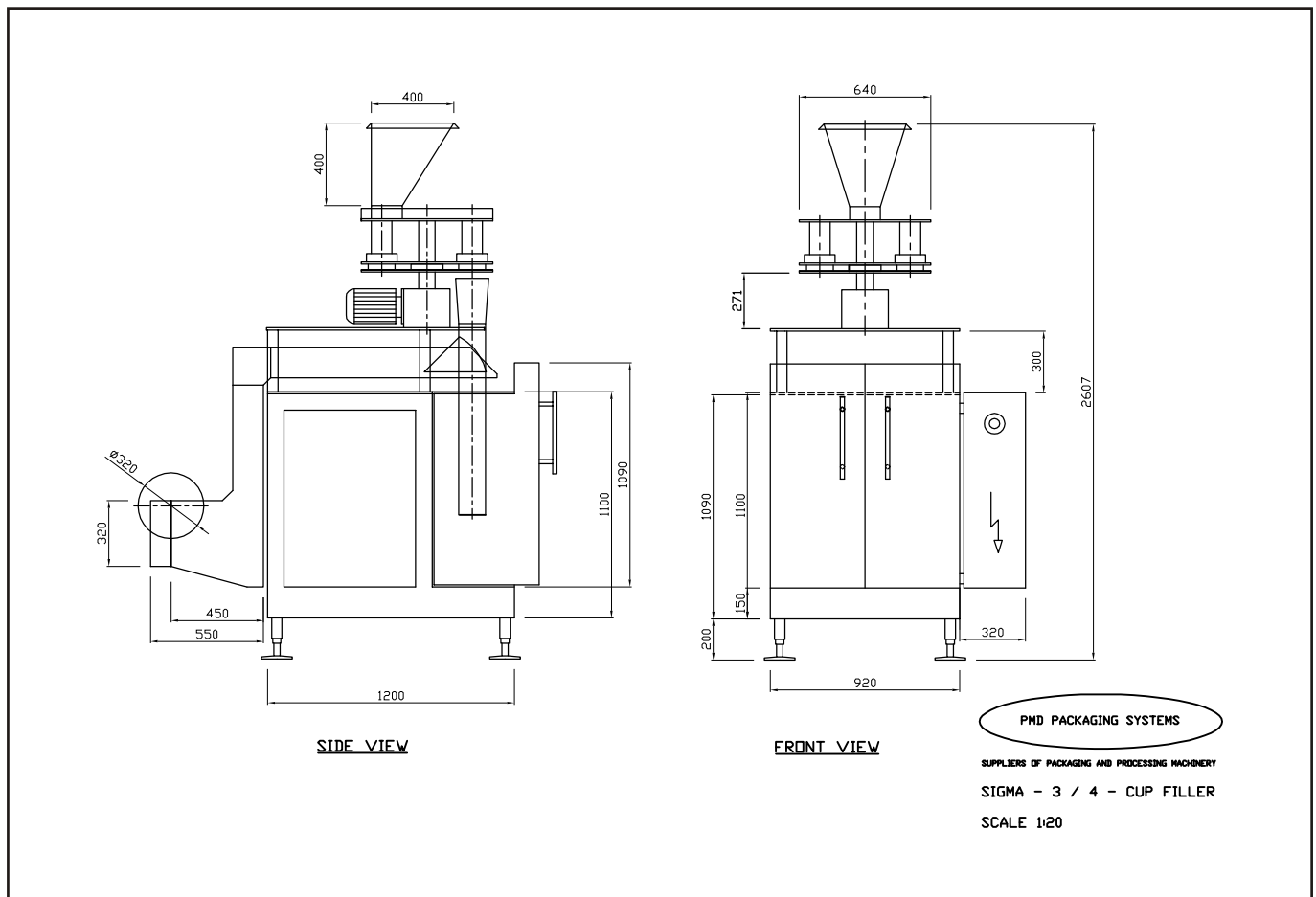

Head Office/Factory: Green Gate Business Park 11; Plot 187 Beyers Naude Drive, Muldersdrift, 1739
PO.Box 3353
Honeydew, 2040
Johannesburg, South Africa

PO.Box 115
Sanlamhof, 7532
Cape Town, South Africa

Suppliers of Packaging and Processing Machinery

Tel: +27 (0) 11 795 1994/ (0)11 794 3869
Fax: +27 (0) 11 795 3870
E-mail: support@pmdpackaging.co.za

Tel: +27 (0) 21 910 4538
Fax: +27 (0) 21 910 4557
E-mail: pmdcape@iafrica.com

PMD PACKAGING SYSTEMS (PTY) LTD

www.pmdpackaging.co.za